

## GD18 'Series 400' Rotary Latch

### Features

- Exceptionally neat and compact design of the 'Series 400' makes it suitable for confined spaces and thin doors
- It provides 2-stage anti-burst latching, with mounting through the pivot points for great strength
- Claw engages pin with 2-stage action, and is released by pull as shown on 2-lobe actuator arm
- Slam-action against striker pin
- Both 'hands' available as illustrated

### Material

- Steel, clear zinc plated

### Product Performance

- Transverse load: Excess of 8,900 N

### Notes

- Plant-on to edge of door, fixing through body of latch with cut-out for actuator arm
- Use with 'remote action' handles, turn-buttons, wire and rod linkages, etc.
- Striker **G00425** sold separately

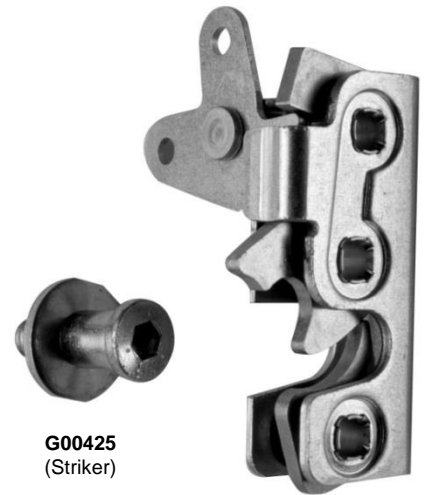

**G00425**  
(Striker)

**GD18-G00424**  
(RH, in unlatched position)

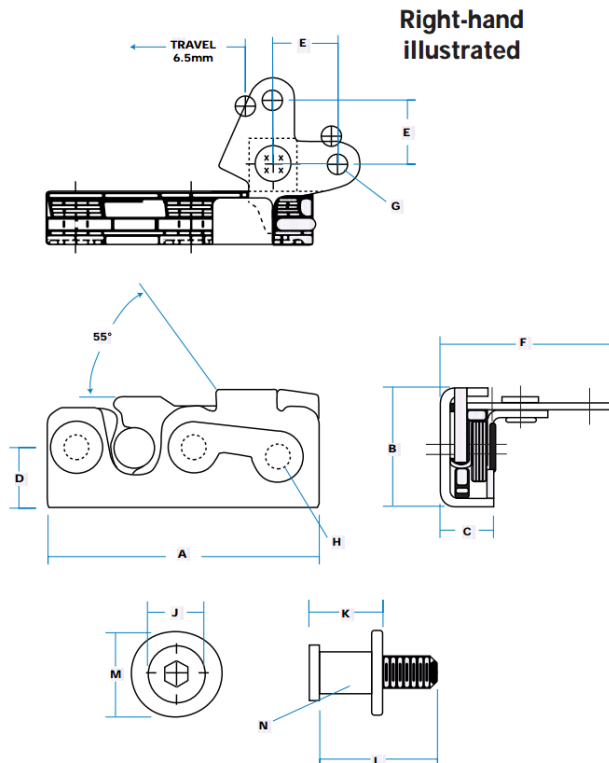

**Striker pin head 8mm hex x 4mm deep**  
**Thread form 14 UNC Class 2A**

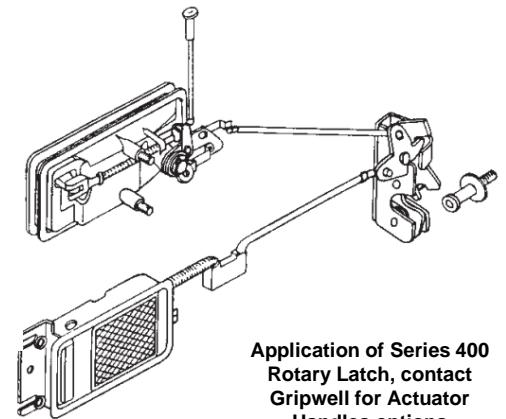

**Application of Series 400**  
**Rotary Latch, contact**  
**Gripwell for Actuator**  
**Handles options**

Part No.	Type	A	B	C	D	E	F	G	H	J	K	L	M	N
GD18-G00423	LH	92	40	20	21	21	59	6.5	8	19	26	44	30	14
GD18-G00424	RH													